

FIBERCADE[®]

TYPE I & TYPE II BARRICADE

All Plastic Barricade
Composed of Replaceable
Component Parts



- All plastic barricade with a double wall design that makes it extremely rigid and strong
- Built from component parts, legs and boards, assuring easy replacement of damaged parts
- Bottom board can carry a 35 lb. sandbag
- Two flashing light mounting receptacles
- NCHRP-350 Certified, meets MUTCD Standards



Choose from 12" x 24",
8" x 24", or 3" x 24" boards
Signs or names can be
stenciled directly on the
plain board or on the
reflective sheeting



PLASTICADE[®]

www.plasticade.com

FIBERCADE®

TYPE I & TYPE II BARRICADE

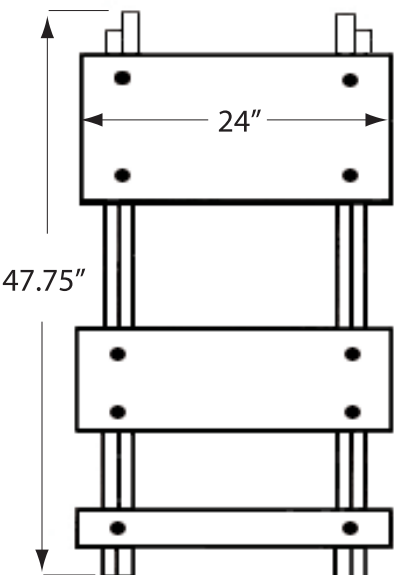

Front View

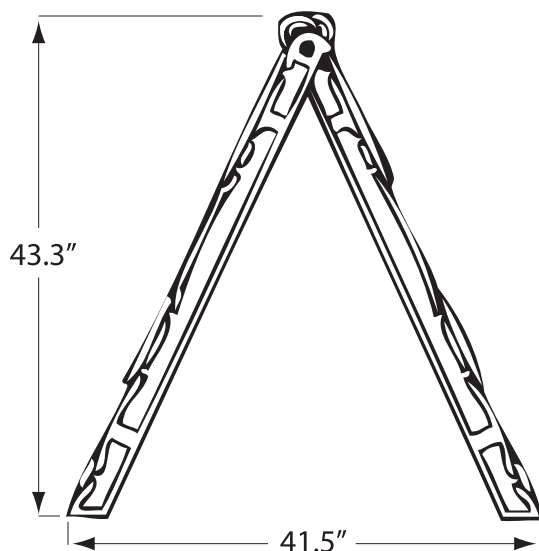

Side View

Specs

Composition	High Density Polyethylene
Dimensions	43.3"H x 24"W x 3"D
Colors	White
Weight	16 lbs.
Reflective Sheeting	Available in all grades in white and orange

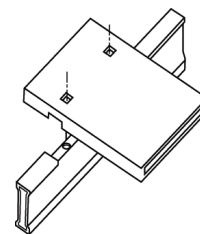

Holes are predrilled in the boards and legs for easy assembly when you purchase component parts



Purchase assembled with your choice of 12" x 24" or 8" x 24" top and bottom panels, with or without sheeting

PLASTICADE®

7700 N. Austin Avenue
Skokie, IL 60077
phone (800) 772-0355
fax (847) 966-8074

www.plasticade.com

MADE IN THE USA